

名称:纳拓银翼EDC中英版说明书
尺寸:95x50mm(成品) 95x300mm(展开)
颜色:PANTONE COOL GRAY 10C
工艺:风琴折页做压痕
材质:105克双铜纸
日期:2022/7/25

NexTool

NE20182 纳拓银翼EDC工具使用说明书

使用产品前请仔细阅读本说明书,并妥善保管

产品特点

1. 以卡片形状设计的EDC多功能小工具,满足你家庭户外全场景使用需求;
2. 小巧精致,尽在“掌”握;
3. 精心选材,匠心打造。

产品结构

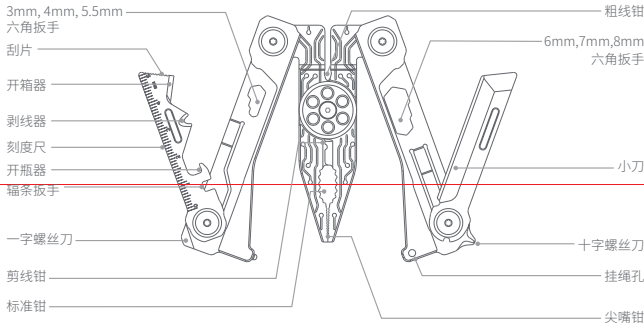

产品参数

产品尺寸	85 × 52 × 7mm (闭合)
主要材质	420J2
产品重量	91g ± 5g

产品保养

1. 使用完应注意清洁,特别是将盐渍、油脂、污垢等彻底洗净,并确保无碎纸片或粉尘堵塞,并且擦干收纳。
2. 必要时可适当用润滑油等涂擦,以确保使用顺畅,防止生锈。
3. 产品能胜任日常活动的正常使用,但是也应避免不必要的超负荷暴力使用,以防变形或损坏。

保修条款

本保修政策是制造商(我们)向最终用户(您)提供保修和其他相关事宜的法律文件,请您妥善保管。如您在购买产品时销售商或其他第三方声明将由其提供保修服务或其他更多服务的,则保修服务或其他服务将由销售商或第三方提供。

一、说明

本保修服务仅适用于符合出厂配置的产品或其部件在保修期内经正常使用后出现保修范围内的性能故障。保修范围内性能故障的界定,如国家有相关规定的,依据国家规定;如无规定,将由我们依据本保修政策判定。

二、保修期

保修期自产品交付之日起算一年。网络、电话或其他非现场交易的交付日以第三方物流记录的交付时间为交付日;其他情形则以发票日为交付日,但如您能证明非因您自身的原因导致发票日早于实际交付日的,经我们确认无异议后可以实际交付日为准。如您无法提供有效的第三方物流交付信息或发票的,则保修日自产品出厂后三十日起算。具体保修期限和其他事宜,请同步见保修卡。

三、服务获取和配合

您可以按照如下方式联系我们以获取保修服务:

- A. 致电:0662-3692722;
- B. 联系您实际购买时的销售平台。

申请保修时,您需提供清晰、完整和准确的①产品发票;②保修卡;③电商平台订单信息(如有);如因您无法提供而不能确认产品来源的,您将无法获取保修服务。

四、保修政策

1. 自保修期起始后7日内,产品出现性能故障,经由我们或我们授权的售后服务中心检测确定,可免费享受退货或换货服务。换货的,保修期将重新计算。
2. 自保修期起始后8-15日内,产品出现性能故障,经由我们或我们授权的售后服务中心检测确定,可免费享受换货或维修服务。换货的,保修期将重新计算。
3. 自保修期起始后12个月内,产品出现性能故障,经由我们或我们授权的售后服务中心检测确定,可免费享受维修或更换服务。维修或更换的产品将在原产品在剩余保修期内继续享有保修服务,剩余保修服务期不足3个月的,则剩余保修期延至3个月。
4. 退货或换货时,您需将产品随附件及包装一并完整退还,并保持产品本身、附属配件、产品外观不存在任何破损、划伤、损坏;维修的,维修时新换上的部件归属于您,旧件将被我们回收。
5. 属于保修范围内的产品硬件故障,由我们承担物流费用和保修产生的其他费用,经确认不属于保修范围内的故障或损坏的,除非同时另有规定,由您承担往返运费(如有)和运输过程中的风险。

五、非保修范围

下列情况将不提供保修:

1. 因误用、意外、改装、私拆、进液等不适当的物理或操作环境,不可抗力,不当维护或保管导致的故障或损坏;
2. 未经我们授权的机构或人员私自拆卸或修理;
3. 产品使用过程中发生的褪色、磨损和消耗;
4. 随产品或部件的相关标签、标识被更改或去除,如:保修凭证上产品信息或序列号与实物不相符合,或有涂改的;
5. 部件有明显的硬物损伤,伤痕、缺角、严重变形、破损等现象;
6. 产品超出保修期。

六、有偿服务

对于超出保修期或保修服务范围之外的产品故障,经确认可由我们提供服务的,我们将提供有偿的专业维修服务,您知悉并同意维修时旧部件将被回收。除非同时另有明确约定,我们将对被维修或更换的零部件提供90天的质保期。

七、一般条款

本服务政策适用中国大陆地区的法律(不包括冲突法)。

如因本文件项下的事宜发生任何争议,友好协商未果的,将提交阳江市江城区有管辖权的人民法院裁决。

保修卡

产品信息	品名	型号
用户信息	姓名	电话
	地址	
销售商信息	名称	电话
	地址/网址	
	销售日期	发票号码

如有售后服务需求,请联系广东百创源科技股份有限公司客服部门
售后服务电话:0662-3692722
服务时间:周一至周五 8:00-17:15
制造商:广东百创源科技股份有限公司
地址:广东省阳江市江城岭科技产业园B9-3



NexTool

User manual of NexTool Silver Blade EDC Tool

Please read this manual before using and keep it carefully

FEATURE

1. EDC multifunctional tool designed in the shape of a card. One tool for many cases.
2. Delicate and portable which could be carry out with one hand.
3. The great material and high quality workmanship.

STRUCTURE

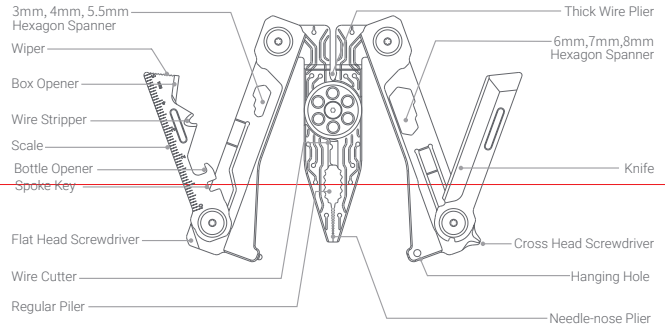

PRODUCT PARAMETER

Dimension	85 × 52 × 7mm (Closed)
Main material	420J2
Weight	91g ± 5g

MAINTENANCE

1. After using, please cleanup the product in time and dry before storing.
2. Apply grease when necessary to ensure smooth use and prevent rust.
3. The product is designed for normal activities, please avoid unnecessary overload or violence test which may cause damage or deformation

WARRANTY

This warranty policy is a legal document we manufacturer provide for our end use, stipulating warranty services and other related matters. Please keep it properly. If the retailer or other third party whom you buy the product from declares that it will provide warranty service or other more services, the warranty service or other services will be provided by the retailer or third party.

1. Instruction

This warranty service is only applicable to the product or its parts that meet the factory configurations during normal use within the warranty period when there is a performance failure within the warranty scope. The definition of performance failures within the warranty scope, if the country has relevant regulations, shall be based on national regulations; if there are no regulations, we will determine it in accordance with this warranty policy.

2. Warranty period

The warranty period is one year from the date of delivery of the product. The delivery date of online, telephone or other off-site transactions is the same as delivery date recorded by the third-party logistics; in other cases, the invoice date should be regarded as delivery date, but if you can effectively prove that the invoice date is earlier than the actual delivery date and it is not caused by your end, the actual delivery date shall prevail with our confirmation. If you are unable to provide valid third-party logistics delivery information or invoices, the warranty date will be calculated from 30 days after the product leaves the factory. Please see the warranty card for the specific warranty period and other matters.

3. How to access to our services

Below optional methods for you to contact us for warranty service:

- A. Service hot-line: 86-662-3692722.
- B. Contact the selling platform where you buy the product.

For warranty application, please submit clear, complete and correct documents including ① invoice; ② warranty card; ③ Order information on E-commerce platform (if applicable).

If you cannot provide above proofs indicating the source of the product, you will not be able to obtain warranty service.

4. Warranty policy

- 1) Within 7 days since the start of the warranty period, if the product has a performance failure, and it is confirmed by us or our authorized after-sales service center, you can enjoy the return or replacement service for free. For replacement product, the warranty period will be recalculated.
- 2) Within 8-15 days since the start of the warranty period, if the product has a performance failure, and it is confirmed by us or our authorized after-sales service center, you can free replacement or repair services. For replacement product, the warranty period will be recalculated.
- 3) Within 12 months since the start of the warranty period, if the product has a performance failure, and it is confirmed by us or our authorized after-sales service center, you can enjoy free repair or component replacement services. The repaired product or product with replaced components will continue to enjoy the warranty service during the remaining of the original product. If the remaining warranty service period is less than 3 months when warranty period the repair or component replacement occurs, the remaining warranty period will be extended to 3 months.
- 4) When return or replacement is required, the product should be in original condition in complete packaging. The main product itself as well as all the accessories should be without any damage, scratches or breakage. For repairs, new components become part of your product, and the components replaced should be returned to us.
- 5) For product hardware failures within scope of warranty, we will bear the logistics costs as well as other costs incurred by the warranty. For the failures or damages that are confirmed not in the coverage of warranty, unless otherwise specified at that time, you shall bear the round-trip freight (if any) and the risks in the transportation process.

5. Non-warranty coverage

Warranty will not be applicable under following occasions:

- 1) Failures or damages caused by improper physical or operating environment, force majeure, improper maintenance or storage, such as misuse, accident, modification, private dismantling, liquid intake, etc.
- 2) Unauthorized organization or personnel dismantle or repair without our authorization;
- 3) Discoloration, wear and consumption during use;
- 4) The relevant labels and marks of the products or parts are changed or removed, such as: the product information or serial number on the warranty certificate does not match the actual product, or has been altered;
- 5) Components with obvious damages by hard objects, scratching marks, broken corners, severe deformations and other breakages.
- 6) Warranty period expires.

6. Paid services

For product failures beyond the warranty period or outside the scope of the warranty service, we will provide paid professional repair services if it is confirmed within our service scope. With your knowledge and agreement, the old components replaced will be recycled when repaired. Unless expressly agreed otherwise, we will provide a 90-day warranty for the repaired or replaced components.

7. General terms

This service policy applies to the laws of mainland China (excluding its conflict laws). If any dispute arises due to the matters under this document and the friendly negotiation fails, it will be submitted to the People's Court with jurisdiction in Jiangcheng District, Yangjiang City for ruling.

WARRANTY CARD

Product Description	Name	Model#
User Information	Name	Phone
	Address	
Retailer Information	Address	Phone
	Address/Website	
	Sale date	Invoice#

For after-sales service needs, please contact the customer service department
After-sales service phone: 86-662-3692722
Business hours: Mon. to Sun. 8:00-17:15
Manufacturer: BINOVO MANUFACTURING CO., LTD.
Address: B9-3 Yining Technology Industrial Park, Jiangcheng District, Yangjiang, Guangdong, China